



# Holy Enterprise Limited

FL.2, No.12 North Ave.1, Industrial Rd. East, Gusan, Guzhen, Zhongshan, Guangdong, China

## Specification

6-GFM-180 12V180AH/10HR

Cells Per Unit	6
Voltage Per Unit	12
Capacity	180AH@10hr-rate to 1.8V per cell @ 25°C
Weight	Approx.52.5KG (Tolerance±3%)
Max. Discharge Current	1800 A(5sec)
Internal Resistance	Approx.4.5 mΩ
Operating Temperature	Discharge: -20°C~50°C Charge: 0°C~40°C Storage: -20°C~50°C
Normal Operating Temperature	25±3°C
Float Charging Voltage	2.25 to 2.27 VDC/unit Average at 25°C
Maximum Charging Current	45.0A
Equalization and Cycle service	2.35 to 2.40 VDC /unit Average at 25°C
Terminal	Terminal: B/NB



## Application

- Alarm Systems
- Electronic Toys
- Medical Equipment
- Cable Television
- Communications Equipment
- Electronic Cash Registers
- Electric Test Equipment
- Emergency lighting Systems
- UPS

Dimension: 530(L) ×206 (W) ×216 (H) (Total 221/244 mm)

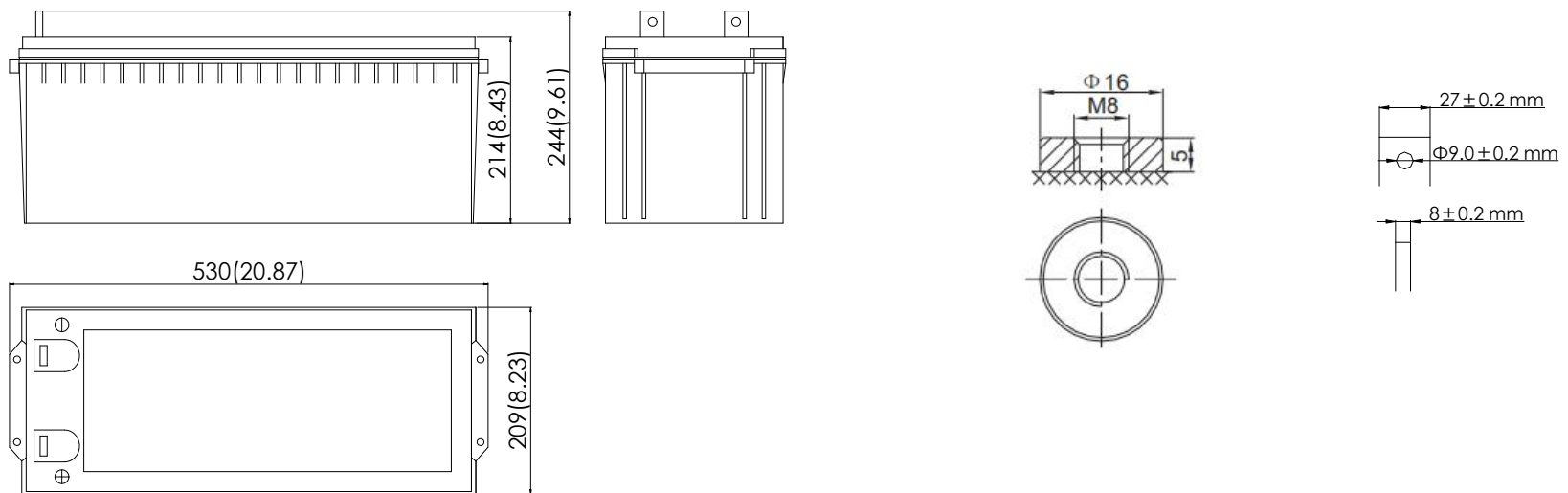

### Constant Current Discharge Characteristics: A(25°C)

F.V/Time	10MIN	15MIN	30MIN	60MIN	2HR	3HR	4HR	5HR	8HR	10HR	20HR
1.80V/cell	279.3	241.5	162.0	95.2	57.1	45.0	35.7	30.6	21.5	18.0	9.44
1.75V/cell	308.5	261.5	169.4	99.0	59.2	46.4	36.8	31.4	21.9	18.2	9.54
1.70V/cell	337.1	281.1	177.3	102.8	61.3	47.9	37.8	32.2	22.2	18.5	9.66
1.65V/cell	366.1	300.1	185.5	106.2	63.4	49.2	38.8	33.1	22.6	18.8	9.78
1.60V/cell	387.5	313.9	193.2	110.0	65.5	50.8	39.9	34.0	22.8	19.0	9.93

### Constant Power Discharge Characteristics: W/Unit(25°C)

F.V/Time	10MIN	15MIN	30MIN	60MIN	2HR	3HR	4HR	5HR	8HR	10HR	20HR
1.80V/cell	3062.4	2684.4	1838.4	1099.2	662.4	524.4	417.6	358.8	254.4	213.6	112.2
1.75V/cell	3325.2	2866.8	1903.8	1136.4	683.4	538.8	429.0	367.2	258.6	216.0	113.4
1.70V/cell	3568.2	3036.6	1971.6	1172.4	705.0	553.2	438.6	375.6	261.6	218.4	114.6
1.65V/cell	3806.4	3194.4	2042.4	1204.2	724.8	566.4	448.8	384.0	265.2	221.4	115.8
1.60V/cell	3951.6	3292.2	2105.4	1240.2	745.2	582.0	459.6	393.0	267.6	223.8	117.6

All mentioned values are average values.

### Discharge Characteristics Curve

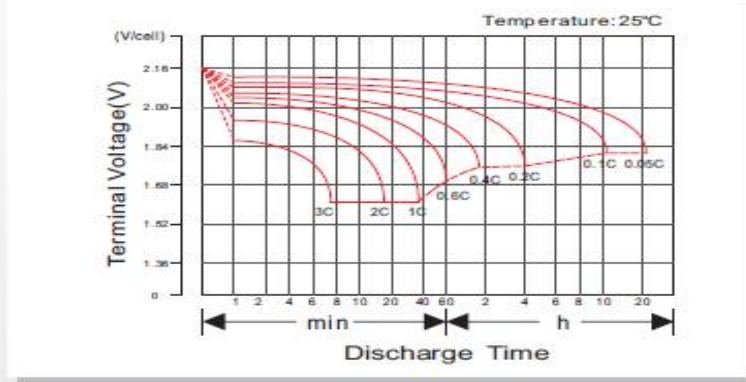

### Charging Characteristics Curve

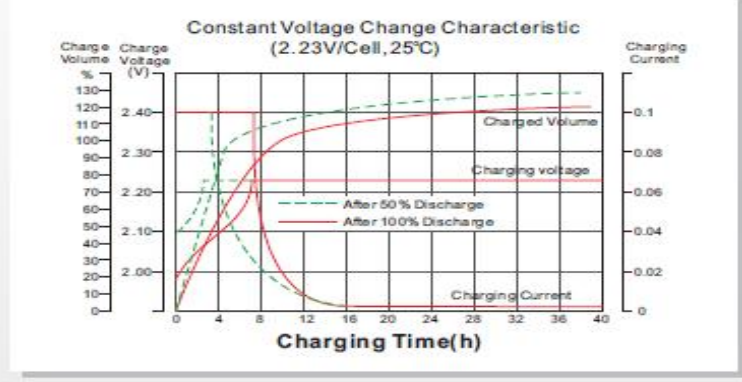

### Cycle life in relation to depth of Discharge

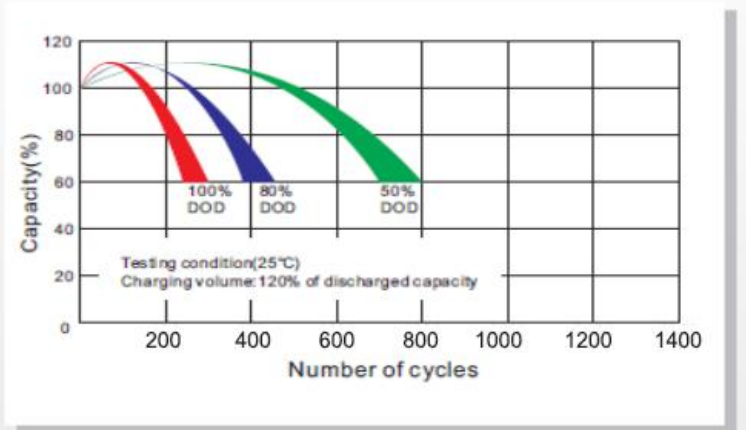

### Temperature effects on Capacity

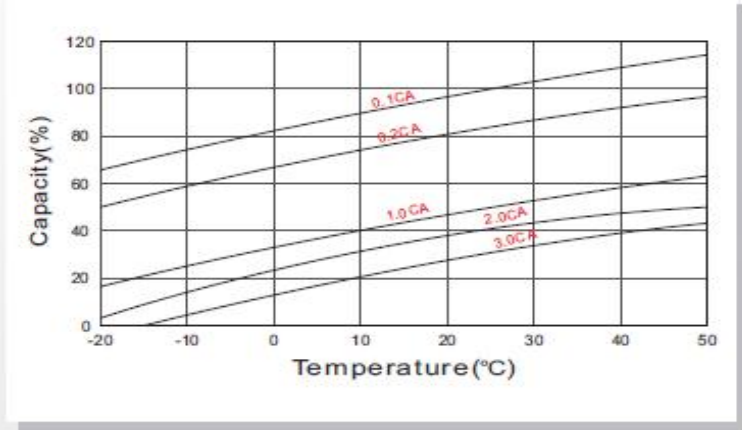

### Relationship between charging voltage and temperature

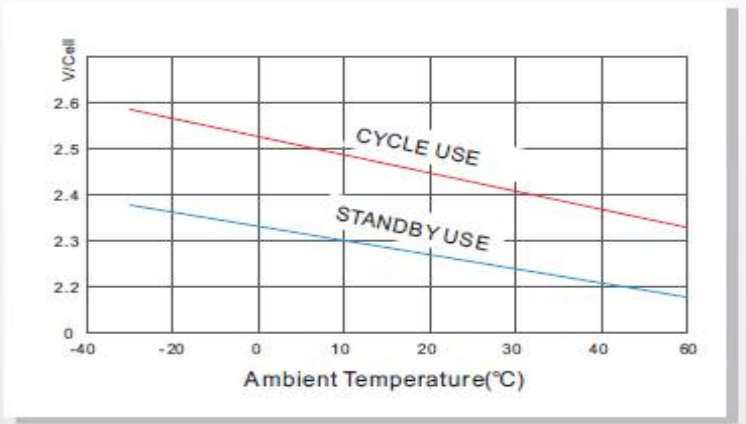

### Self-discharge Characteristics

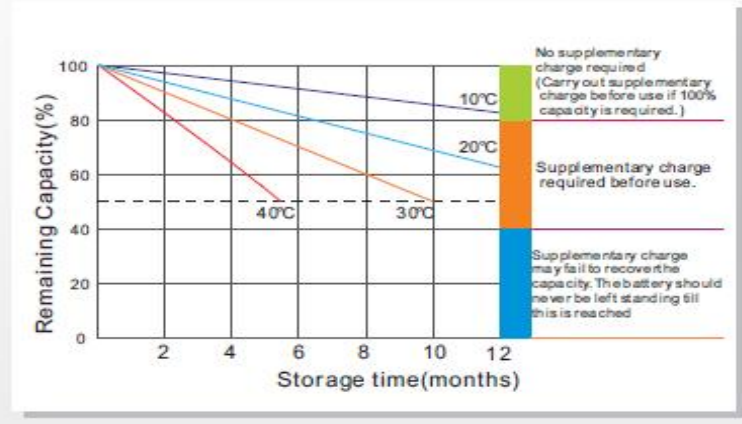

### Temperature effects on Float life

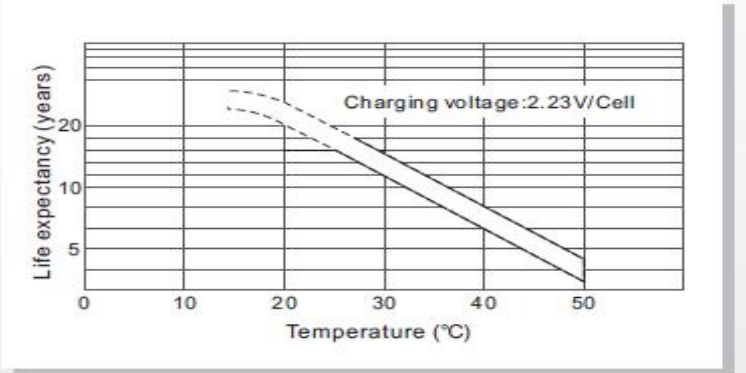

### Life Characteristics of Standby use

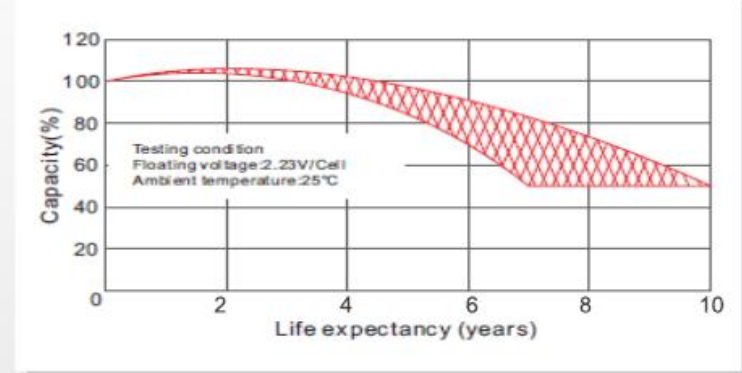

### Maintenance & Cautions

- ※ Every month, recommend inspection every battery voltage;
- ※ Every three months, recommend equalization charge once;  
Equalization charge method:  
Discharge: 100% rate capacity discharge;  
Charge: Max. Current 0.3CA, constant voltage 2.35-2.4V/Cell;
- ※ Effect of temperature on float charge voltage: -3mV/Cell;

### Contact Us

**Add:** FL.2, No.12 North Ave.1, Industrial Rd. East, Gusan, Guzhen, Zhongshan, Guangdong, China,  
**T:** +86-760- 8862 5562 | **F:** +86-760-8862 5562  
**Email:** [sales@holybattery.com](mailto:sales@holybattery.com) [johny5@126.com](mailto:johny5@126.com)  
**Website:** [www.holybattery.com](http://www.holybattery.com)