



Holy Enterprise Limited

FL.2, No.12 North Ave.1, Industrial Rd. East, Gusan, Guzhen, Zhongshan, Guangdong, China

Specification

6-EVF-100-12V100AH/3HR

Cells Per Unit	6
Voltage Per Unit	12
Capacity	100AH@3hr-rate to 1.75V per cell @ 25°C
Weight	Approx.: 35.00kg (Tolerance±3%)
Max. Discharge Current	1000A(5sec)
Internal Resistance	Approx 6.0mΩ
Operating Temperature	Discharge: -20°C~50°C Charge: 0°C~40°C Storage: -20°C~50°C
Normal Operating Temperature	25±3°C
Float Charging Voltage	13.6 to 13.8 VDC/unit Average at 25°C
Maximum Charging Current	16.60A
Equalization and Cycle service	14.5 to 14.9 VDC /unit Average at 25°C
Terminal	Terminal: M6/M8



Application

- Electric golf carts
- Electric wheelchairs
- Cleaning machines
- Electric Vehicles
- Power Tools
- Mowers

Dimension: 328(L) ×172(W) ×215(H) (Total 220 mm)

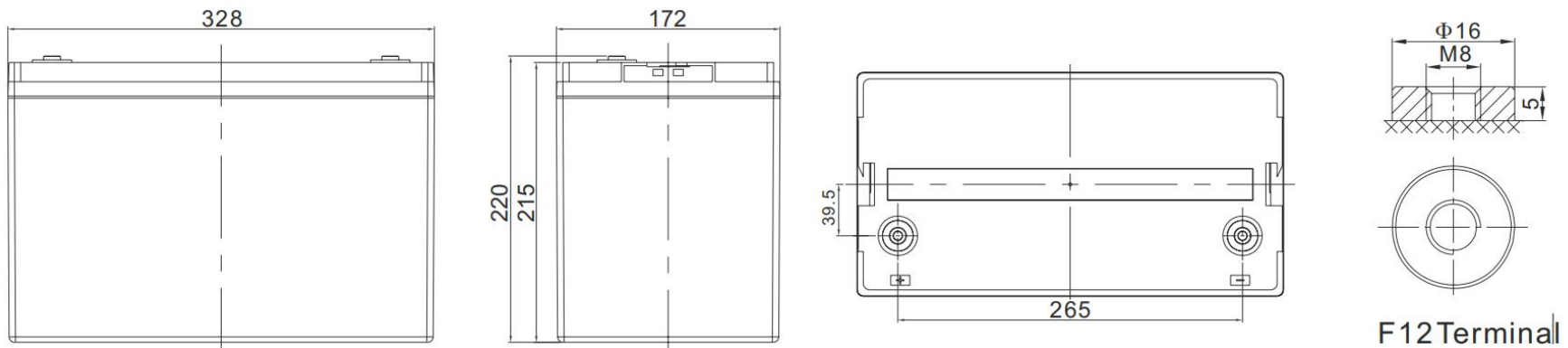

Constant Current Discharge Characteristics: A(25°C)

F.V/Time	5MIN	10MIN	15MIN	30MIN	1HR	2HR	3HR	4HR	5HR
9.60V	408.2	297.9	243.1	151.0	87.10	52.12	36.02	29.52	24.17
10.0V	396.4	283.5	238.1	148.5	86.70	51.73	35.89	29.39	24.02
10.2V	384.6	273.4	234.4	147.2	85.89	51.33	35.61	29.25	23.88
10.5V	345.4	252.3	223.1	143.5	85.09	50.94	35.47	28.98	23.60
10.8V	311.8	230.1	205.7	137.2	83.08	50.03	34.51	28.29	23.17

Constant Power Discharge Characteristics: W/Cell(25°C)

F.V/Time	5MIN	10MIN	15MIN	30MIN	1HR	2HR	3HR	4HR	5HR
9.60V	4222	3173	2674	1721	1006	614.3	428.7	351.9	288.3
10.0V	4139	3075	2631	1700	1004	611.0	428.1	351.5	287.6
10.2V	4092	2994	2601	1688	996.3	607.4	427.0	350.7	286.6
10.5V	3752	2788	2481	1649	987.4	602.9	425.3	347.4	283.2
10.8V	3393	2570	2294	1580	969.1	595.3	413.7	339.5	287.0

All mentioned values are average values.

Charge Characteristic Curve For Cycle Use(IUI)

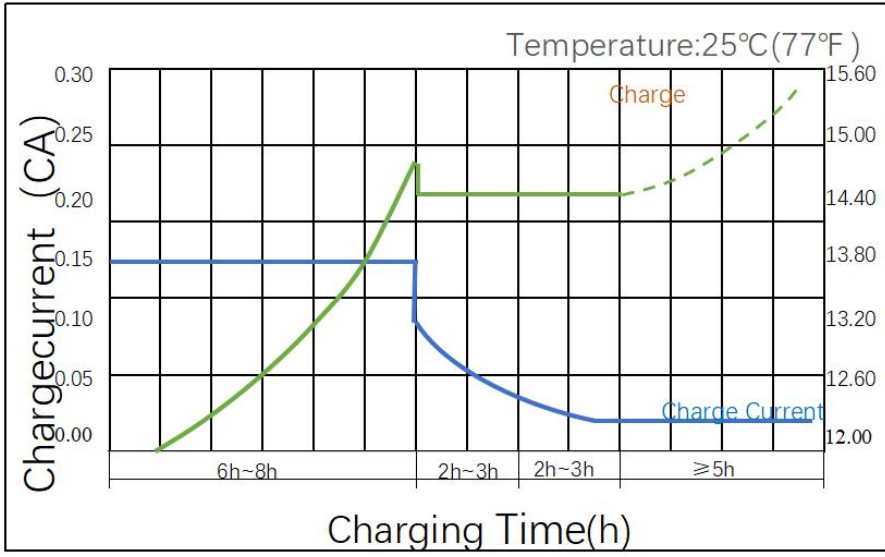

Cycle Life in Relation to Depth of Discharge

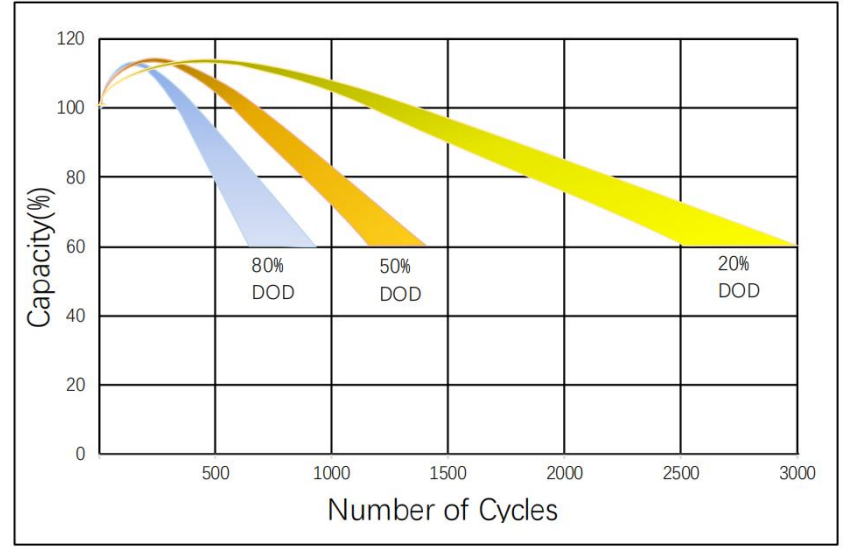

Storage Characteristics

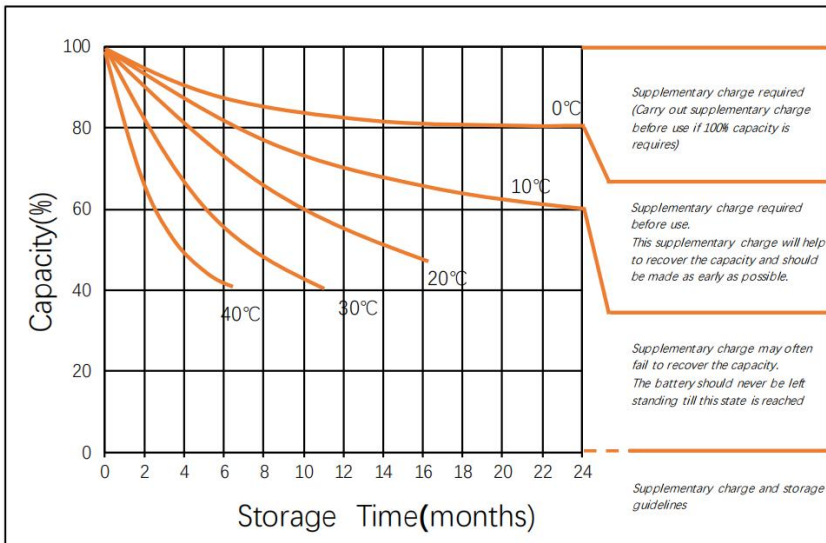

Discharge Characteristics Curve

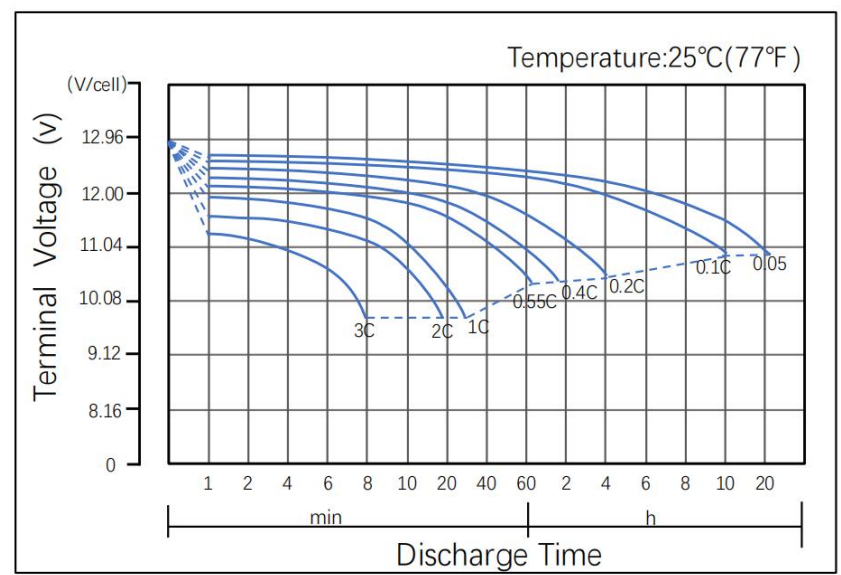

Relationship Between Charging Voltage and Temperature

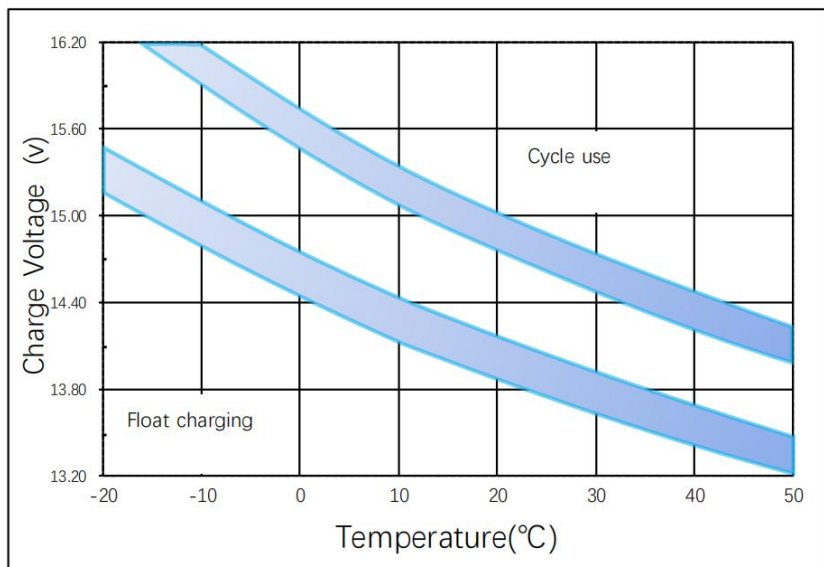

Temperature Effects on Capacity

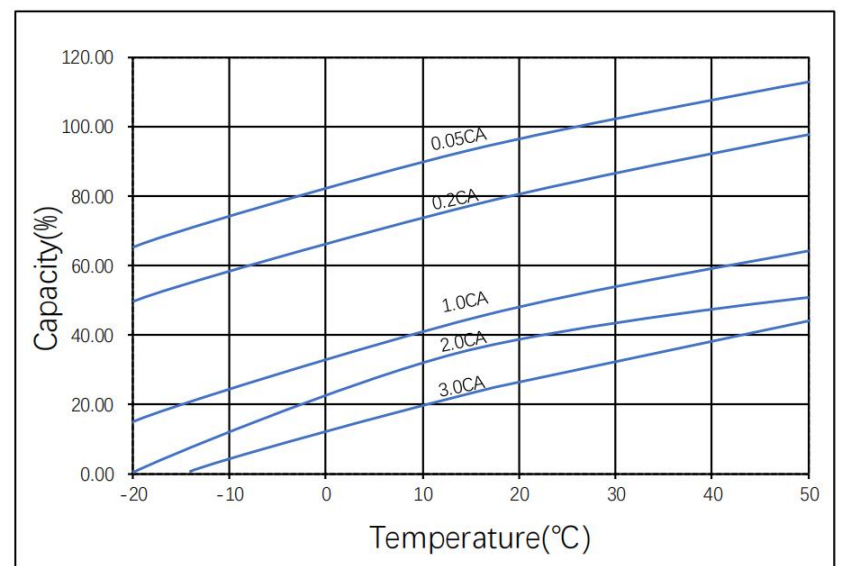

Maintenance & Cautions

- ※ Every month, recommend inspection every battery voltage;
- ※ Every three months, recommend equalization charge once;
Equalization charge method:
Discharge: 100% rate capacity discharge;
Charge: Max. Current 0.3CA, constant voltage 2.35-2.4V/Cell;
- ※ Effect of temperature on float charge voltage: -3mV/Cell;

CONTACT Us

Add: FL.2, No.12 North Ave.1, Industrial Rd. East, Gusan, Guzhen, Zhongshan, Guangdong, China,
T: +86-760- 8862 5562 | **F:** +86-760-8862 5562
Email: sales@holybattery.com johny5@126.com
Website: www.holybattery.com