



# Holy Enterprise Limited

FL.2, No.12 North Ave.1, Industrial Rd. East, Gusan, Guzhen, Zhongshan, Guangdong, China

## Specification

6-EVF-150-12V150AH/3HR

Cells Per Unit	6
Voltage Per Unit	12
Capacity	150AH@3hr-rate to 1.75V per cell @ 25°C
Weight	Approx.: 51.0kg (Tolerance±3%)
Max. Discharge Current	1500A(5sec)
Internal Resistance	Approx 4.5mΩ
Operating Temperature	Discharge: -20°C~50°C Charge: 0°C~40°C Storage: -20°C~50°C
Normal Operating Temperature	25±3°C
Float Charging Voltage	13.6 to 13.8 VDC/unit Average at 25°C
Maximum Charging Current	25.5A
Equalization and Cycle service	14.5 to 14.9 VDC /unit Average at 25°C
Terminal	Terminal: F14/M8



## Application

- Electric golf carts
- Electric wheelchairs
- Cleaning machines
- Electric Vehicles
- Power Tools
- Mowers

Dimension: 483(L) ×170(W) ×241(H) (Total 241 mm)

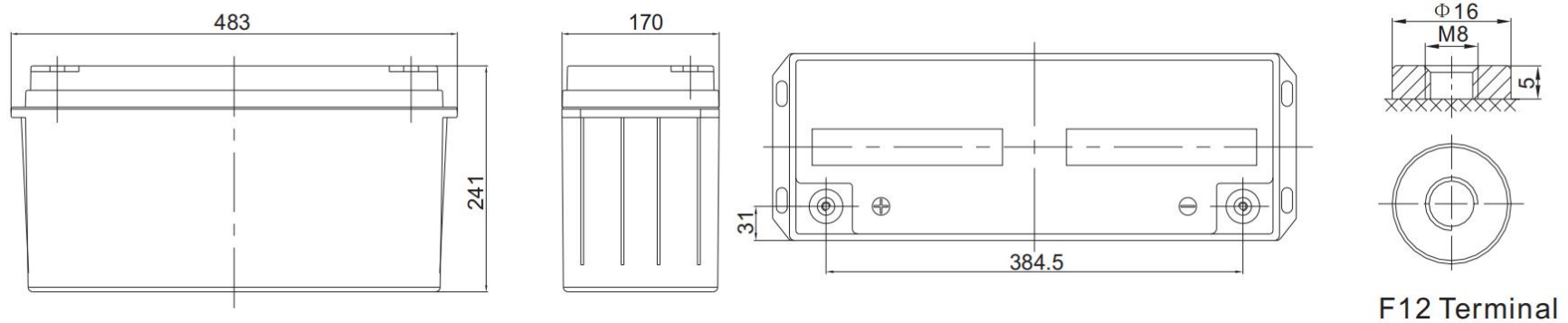

F12 Terminal

### Constant Current Discharge Characteristics: A(25°C)

F.V/Time	5MIN	10MIN	15MIN	30MIN	1HR	2HR	3HR	4HR	5HR
9.60V	545.1	408.33	344.7	225.3	130.0	77.78	53.77	44.05	36.07
10.0V	529.3	388.5	337.6	221.6	129.4	77.20	53.56	43.86	35.86
10.2V	513.6	374.8	332.3	219.6	128.2	76.62	53.15	43.65	35.63
10.5V	461.2	345.8	316.4	214.1	127.0	76.03	52.94	43.23	35.22
10.8V	416.3	315.4	291.6	204.7	124.0	74.67	51.50	42.22	34.58

### Constant Power Discharge Characteristics: W/Cell(25°C)

F.V/Time	5MIN	10MIN	15MIN	30MIN	1HR	2HR	3HR	4HR	5HR
9.60V	5638	4348	3791	2568	1502	916	639.8	525.2	430.2
10.0V	5527	4215	3730	2537	1498	912	638.2	524.5	429.2
10.2V	5464	4104	3688	2519	1487	906	637.2	523.4	427.7
10.5V	4974	3821	3518	2460	1473	899	634.6	518.5	422.6
10.8V	4530	3522	3252	2358	1446	888	617.5	506.7	414.9

All mentioned values are average values.

### Charge Characteristic Curve For Cycle Use(IUI)

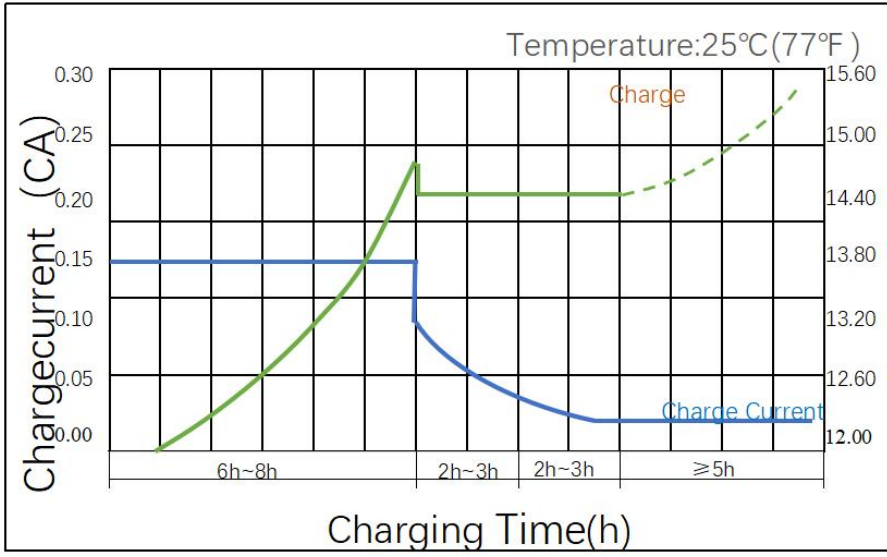

### Cycle Life in Relation to Depth of Discharge

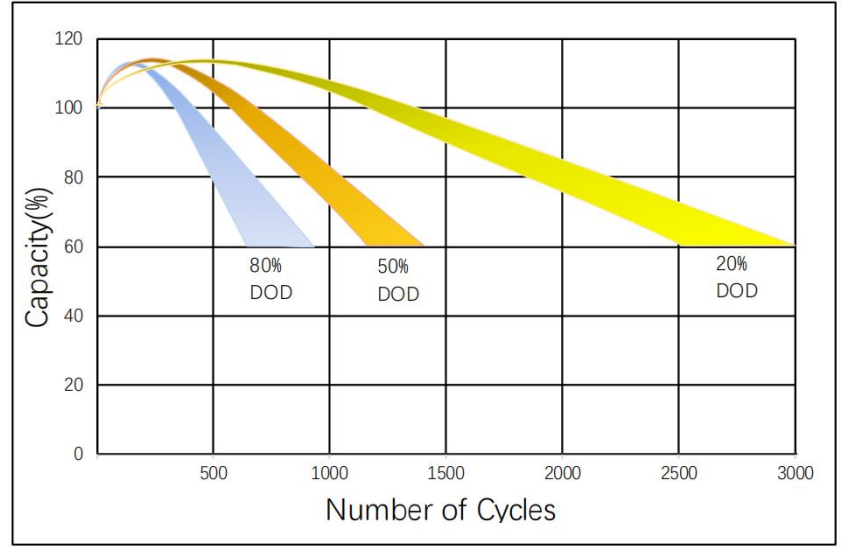

### Storage Characteristics

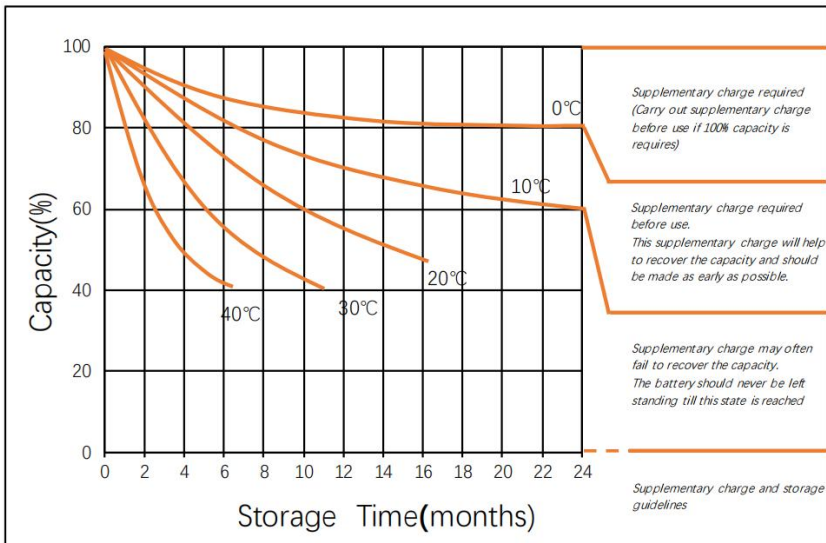

### Discharge Characteristics Curve

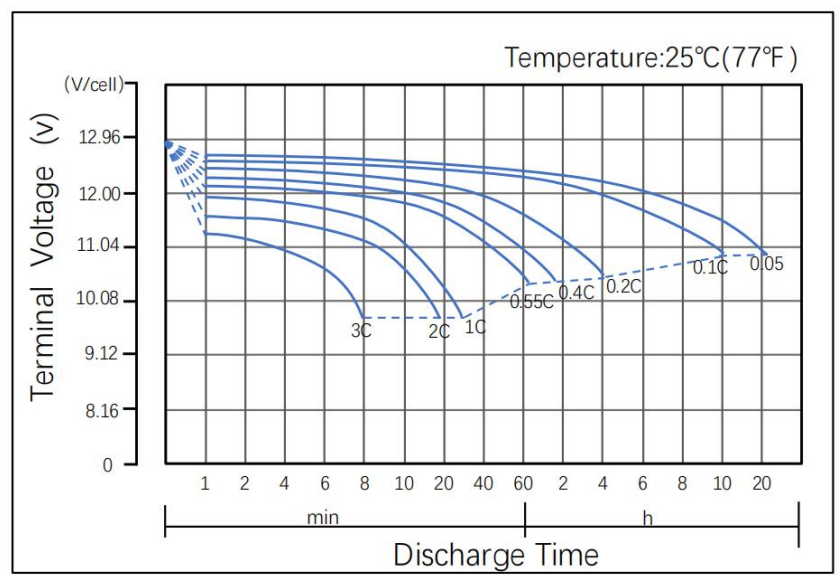

### Relationship Between Charging Voltage and Temperature

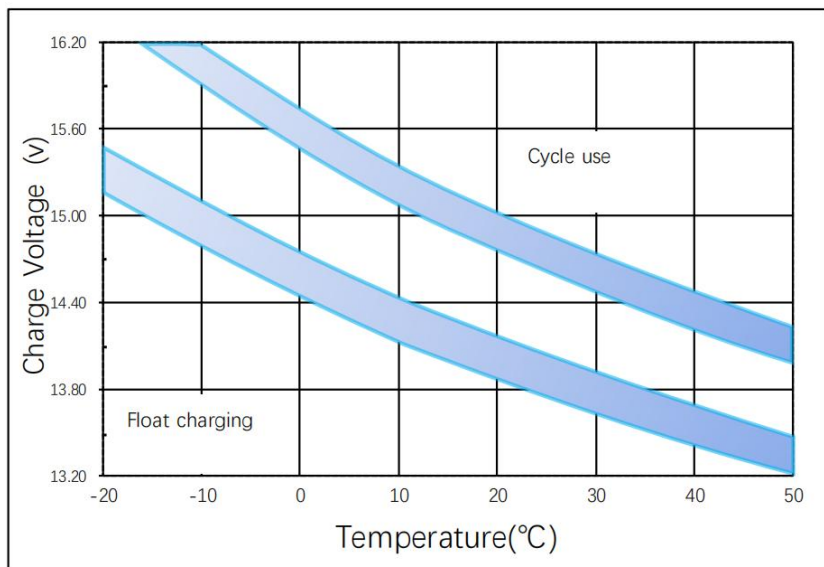

### Temperature Effects on Capacity

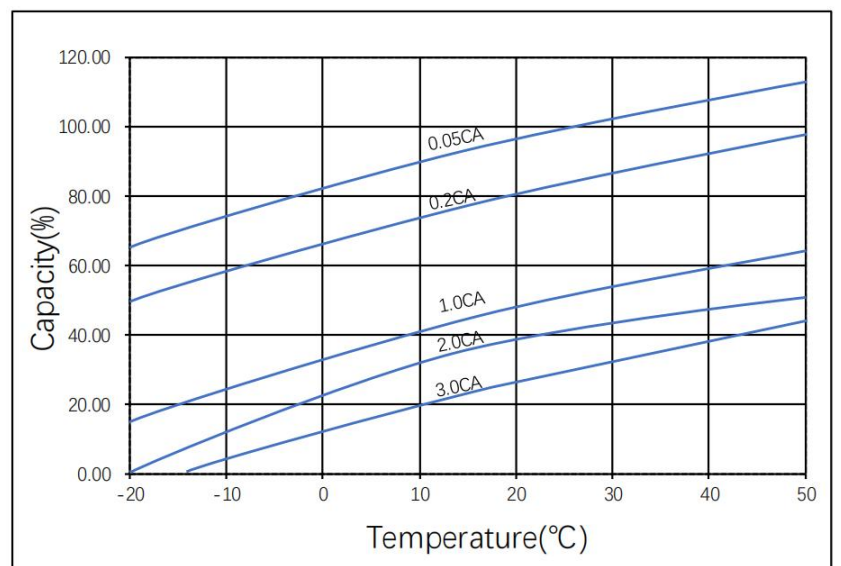

### Maintenance & Cautions

- ※ Every month, recommend inspection every battery voltage;
- ※ Every three months, recommend equalization charge once;  
Equalization charge method:  
Discharge: 100% rate capacity discharge;  
Charge: Max. Current 0.3CA, constant voltage 2.35-2.4V/Cell;
- ※ Effect of temperature on float charge voltage: -3mV/Cell;

### CONTACT Us

**Add:** FL.2, No.12 North Ave.1, Industrial Rd. East, Gusan, Guzhen, Zhongshan, Guangdong, China,  
**T:** +86-760- 8862 5562 | **F:** +86-760-8862 5562  
**Email:** [sales@holybattery.com](mailto:sales@holybattery.com) [johny5@126.com](mailto:johny5@126.com)  
**Website:** [www.holybattery.com](http://www.holybattery.com)