



Holy Enterprise Limited

FL.2, No.12 North Ave.1, Industrial Rd. East, Gusan, Guzhen, Zhongshan, Guangdong, China

Specification

OPzV1500-2V1500AH/10HR

Cells Per Unit	1
Voltage Per Unit	2
Capacity	1500AH@10hr-rate to 1.8V per cell @ 25°C
Weight	Approx. 113.5kg (Tolerance±3%)
Max. Discharge Current	4500A(5sec)
Internal Resistance	Approx 0.45 mΩ
Operating Temperature Range	Discharge: -20°C~50°C Charge: 0°C~40°C Storage: -20°C~50°C
Normal Operating Temperature	25±3°C
Float Charging Voltage	2.25 to 2.27 VDC/unit Average at 25°C
Maximum Charging Current	300A
Equalization and Cycle service	2.35 to 2.40 VDC /unit Average at 25°C
Terminal	Terminal: M8



Application

Uninterruptible Power System;
Communication Equipments;
Solar Power Systems;
Solar Power Street Light;

Dimension: 210(L) × 275(W) × 795(H) (Total 830 mm)

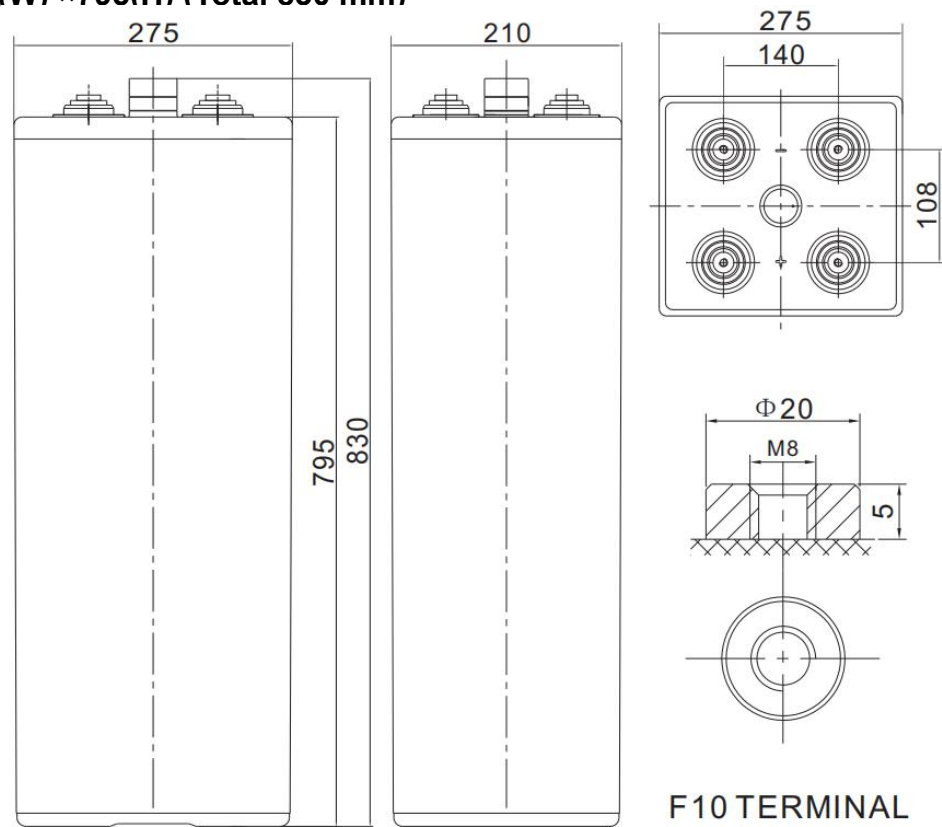

Constant Current Discharge Characteristics: A(25°C)

F.V/Time	10MIN	15MIN	30MIN	1HR	2HR	3HR	5HR	8HR	10HR	20HR
1.65V	1540	1352	1069	836.0	533.0	398.9	268.4	185.9	155.6	81.70
1.70V	1434	1281	1028	814.7	524.6	391.7	264.2	183.8	154.3	80.98
1.75V	1277	1174	972.3	780.6	511.7	384.0	260.3	181.1	152.6	80.13
1.80V	1079	1049	911.6	750.7	494.5	375.5	255.2	178.1	150.0	78.75
1.85V	877.7	866.1	783.0	669.7	451.6	345.2	236.8	166.5	140.6	73.83

Constant Power Discharge Characteristics: W(25°C)

F.V/Time	10MIN	15MIN	30MIN	1HR	2HR	3HR	5HR	8HR	10HR	20HR
1.65V	2668	2458	1963	1574	1019	767.2	520.6	365.2	307.8	161.6
1.70V	2529	2363	1907	1544	1002	754.3	516.4	361.9	305.1	160.2
1.75V	2294	2197	1820	1493	980.4	741.5	507.8	358.0	302.1	158.6
1.80V	1973	1991	1725	1446	958.9	728.7	499.4	352.8	29739	156.4
1.85V	1633	1668	1495	1292	877.2	673.3	465.2	330.1	279.4	146.7

All mentioned values are average values.

Discharge Characteristics(25°C)

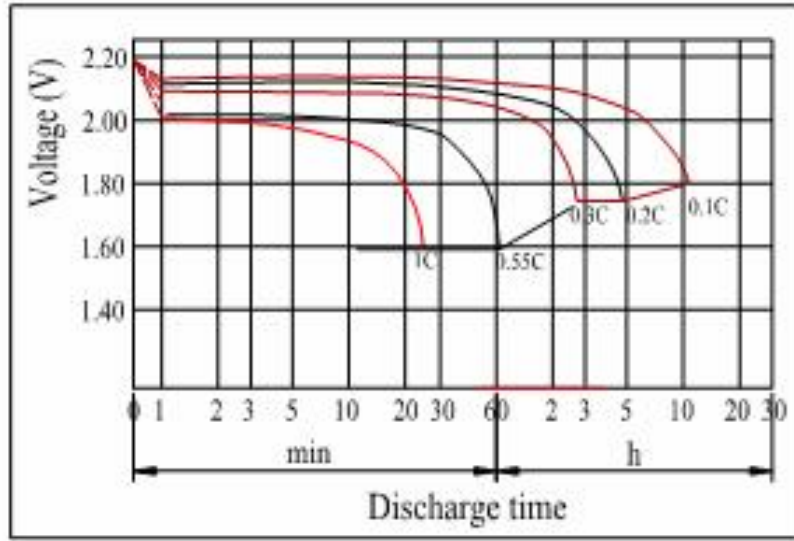

Charging Characteristics(25°C)

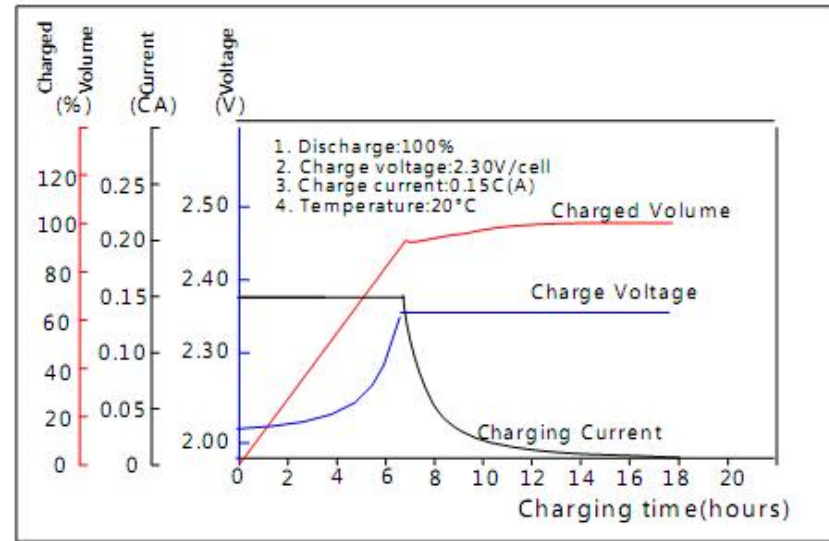

Effect of Temperature on Capacity

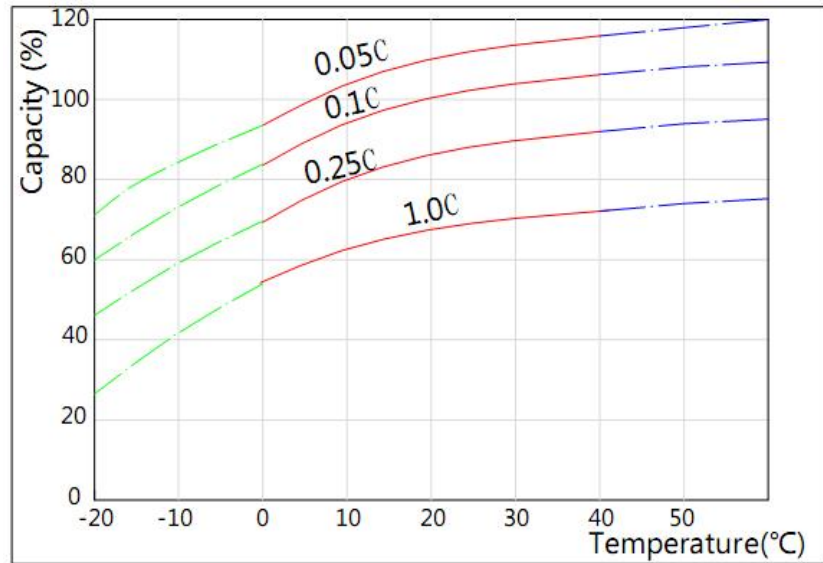

Self-discharge Characteristics

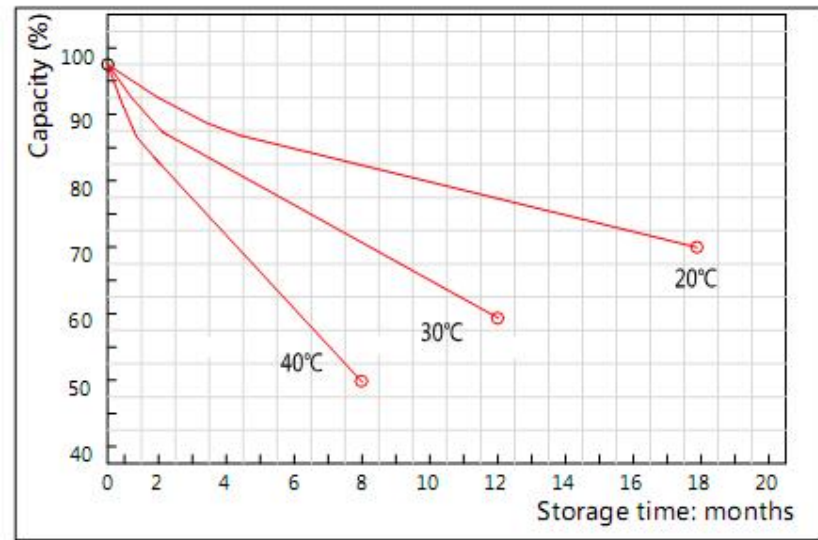

Open Circuit Voltage and Residual Capacity (25°C)

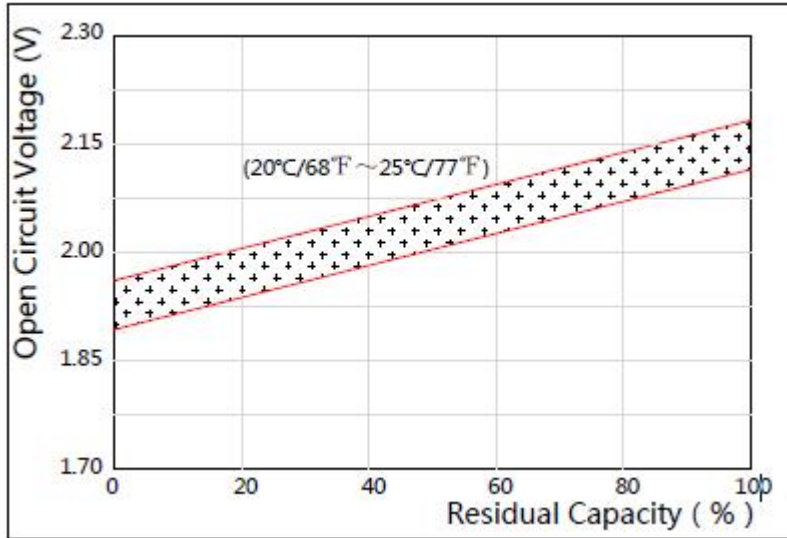

Charging Voltage and Temperature

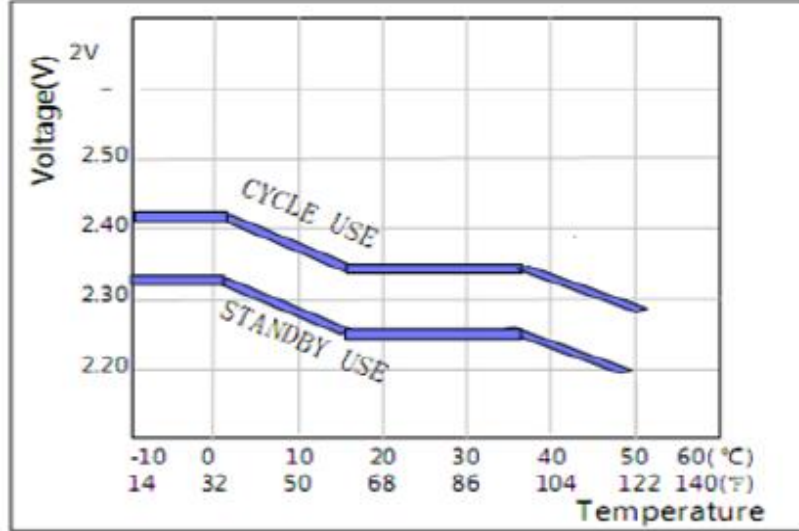

Floating Life on Temperature

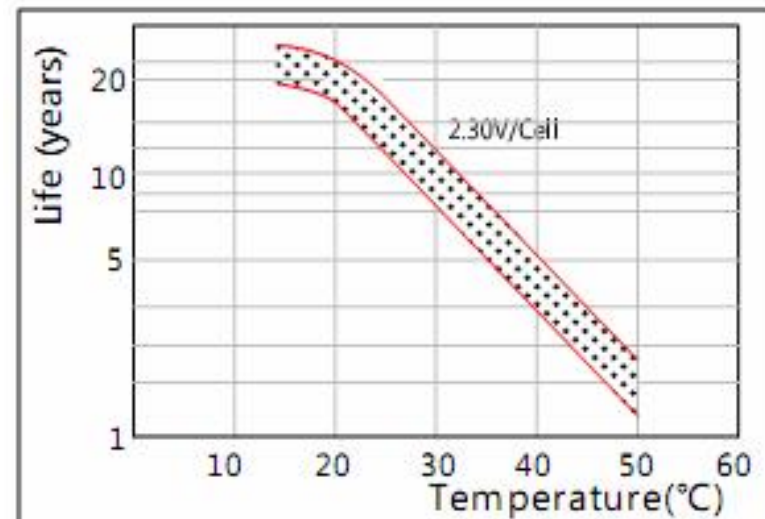

Cycle Life on D.O.D(25°C)

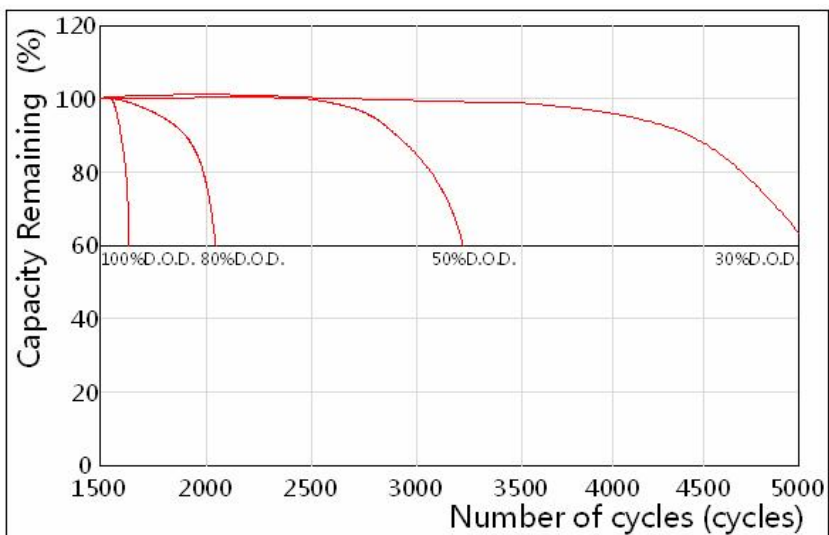

Maintenance & Cautions

- ※ Every month, recommend inspection every battery voltage;
- ※ Every three months, recommend equalization charge once;
Equalization charge method:
Discharge: 100% rate capacity discharge;
Charge: Max. Current 0.3CA, constant voltage 2.35-2.4V/Cell;
- ※ Effect of temperature on float charge voltage: -3mV/Cell;

CONTACT Us

Add: FL.2, No.12 North Ave.1, Industrial Rd. East, Gusan, Guzhen, Zhongshan, Guangdong, China,
T: +86-760- 8862 5562 | **F:** +86-760-8862 5562
Email: sales@holybattery.com johny5@126.com
Website: www.holybattery.com