



Holy Enterprise Limited

FL.2, No.12 North Ave.1, Industrial Rd. East, Gusan, Guzhen, Zhongshan, Guangdong, China

Specification

OPzV500-2V500AH/10HR

Cells Per Unit	1
Voltage Per Unit	2
Capacity	500AH@10hr-rate to 1.8V per cell @ 25°C
Weight	Approx.39.5kg (Tolerance±3%)
Max. Discharge Current	2000A(5sec)
Internal Resistance	Approx 0.70 mΩ
Operating Temperature	Discharge: -20°C~50°C Charge: 0°C~40°C Storage: -20°C~50°C
Normal Operating Temperature	25±3°C
Float Charging Voltage	2.25 to 2.27 VDC/unit Average at 25°C
Maximum Charging Current	100A
Equalization and Cycle service	2.35 to 2.40 VDC /unit Average at 25°C
Terminal	Terminal: M8



Application

Uninterruptible Power System;
Communication Equipments;
Solar Power Systems;
Solar Power Street Light;

Dimension: 166(L) ×206(W) ×470(H) (Total 505 mm)

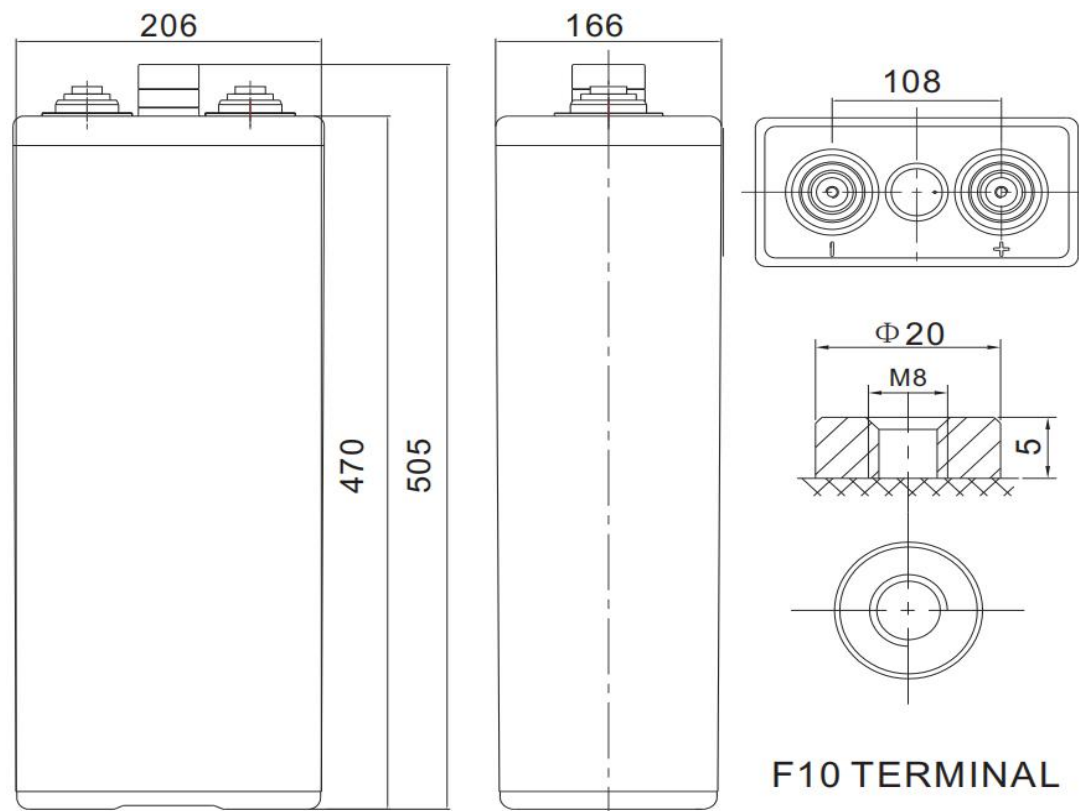

Constant Current Discharge Characteristics: A(25°C)

F.V/Time	10MIN	15MIN	30MIN	1HR	2HR	3HR	5HR	8HR	10HR	20HR
1.65V	690.9	570.6	410.1	278.7	177.8	132.9	89.55	61.88	51.75	27.17
1.70V	644.9	541.9	395.4	271.5	174.8	130.4	88.06	61.13	51.50	27.04
1.75V	573.2	494.9	373.4	260.2	170.6	128.0	86.81	60.38	50.75	26.64
1.80V	485.3	443.2	348.4	250.2	164.8	125.2	85.07	59.32	50.03	26.25
1.85V	395.1	365.2	299.4	223.2	150.4	115.1	78.85	55.37	46.72	24.54

Constant Power Discharge Characteristics: W(25°C)

F.V/Time	10MIN	15MIN	30MIN	1HR	2HR	3HR	5HR	8HR	10HR	20HR
1.65V	1199.7	1013.3	753.6	524.7	339.6	255.6	173.6	121.8	102.5	53.81
1.70V	1137.1	973.4	731.6	514.5	333.9	251.3	172.1	120.5	101.7	53.42
1.75V	1030.9	905.2	697.3	497.6	326.7	247.3	169.4	119.2	100.8	52.89
1.80V	887.8	820.2	660.5	482.1	319.7	243.2	166.4	117.6	99.27	52.11
1.85V	735.1	688.1	571.8	430.5	292.3	224.7	150.0	110.0	93.28	48.96

All mentioned values are average values.

Discharge Characteristics(25°C)

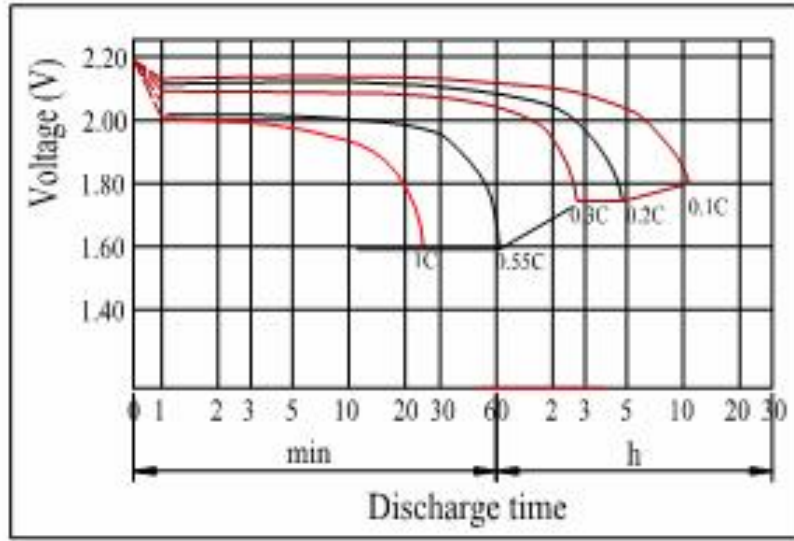

Charging Characteristics(25°C)

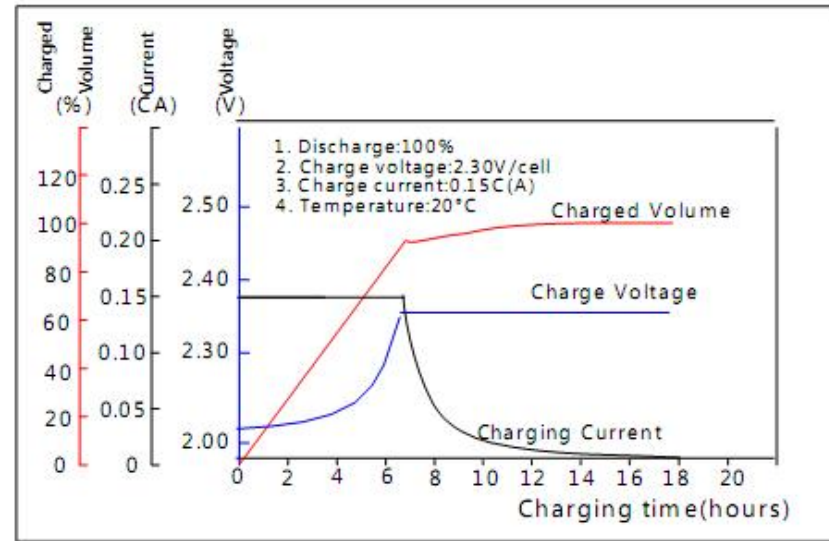

Effect of Temperature on Capacity

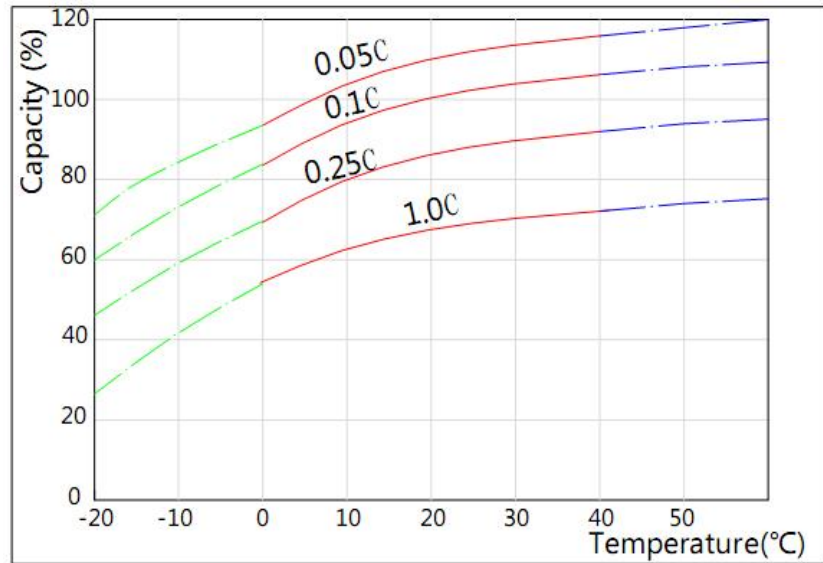

Self-discharge Characteristics

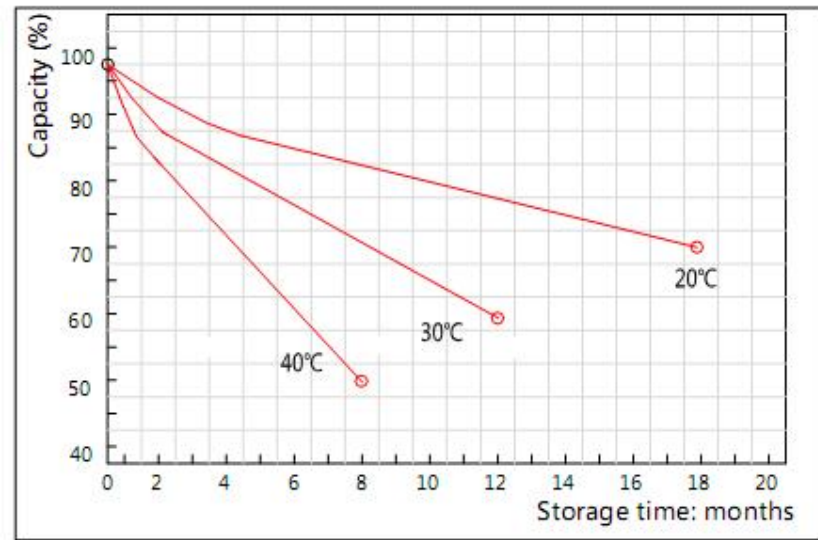

Open Circuit Voltage and Residual Capacity (25°C)

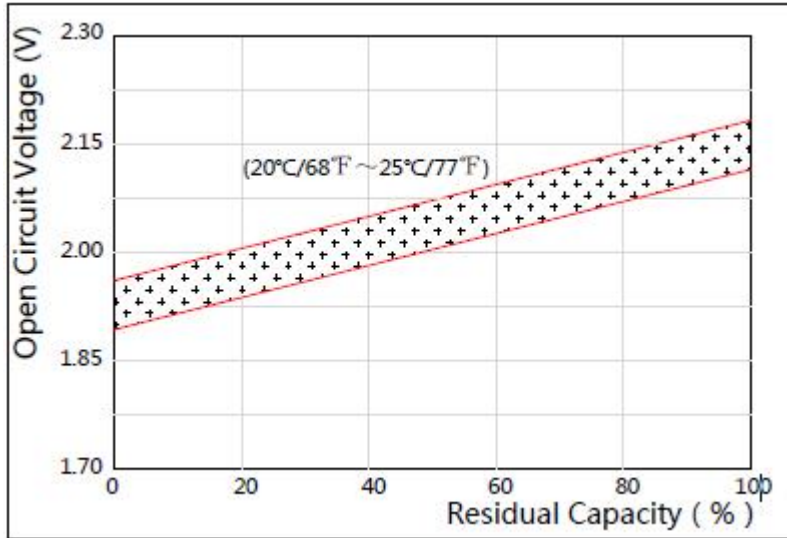

Charging Voltage and Temperature

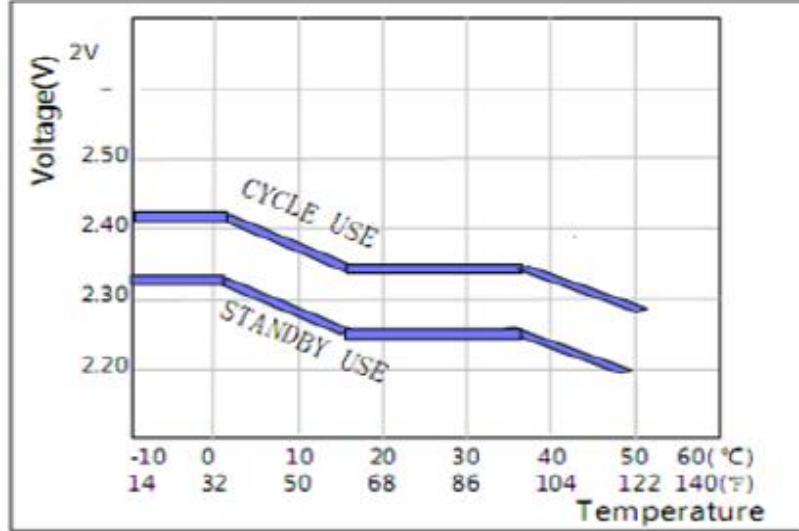

Floating Life on Temperature

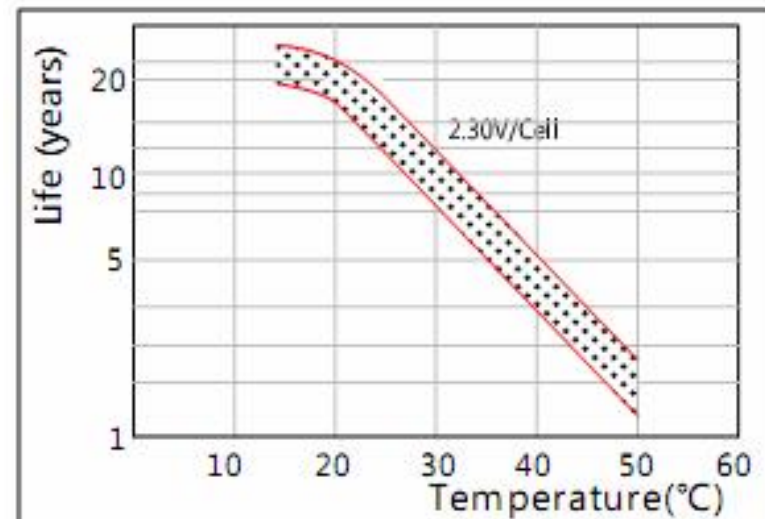

Cycle Life on D.O.D(25°C)

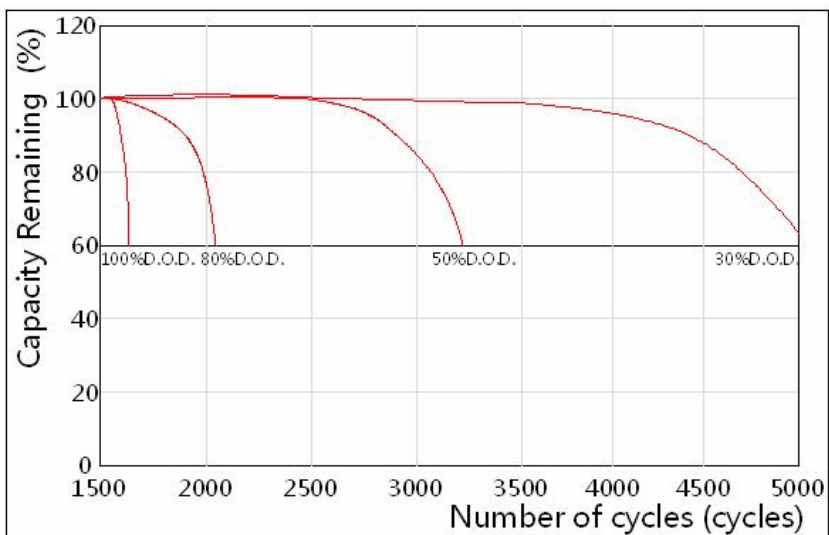

Maintenance & Cautions

- ※ Every month, recommend inspection every battery voltage;
- ※ Every three months, recommend equalization charge once;
Equalization charge method:
Discharge: 100% rate capacity discharge;
Charge: Max. Current 0.3CA, constant voltage 2.35-2.4V/Cell;
- ※ Effect of temperature on float charge voltage: -3mV/Cell;

CONTACT Us

Add: FL.2, No.12 North Ave.1, Industrial Rd. East, Gusan, Guzhen, Zhongshan, Guangdong, China,
T: +86-760- 8862 5562 | **F:** +86-760-8862 5562
Email: sales@holybattery.com johny5@126.com
Website: www.holybattery.com